

## Design and Optimization of Composite Propeller Shaft

More S.D.<sup>1</sup>, Swami M.C.<sup>2</sup>

<sup>1</sup>(Mechanical Engineering, M.S.Bidwe Engineering College, Latur, India)

<sup>2</sup>(Assistant Professor, M.S.Bidwe Engineering College, Latur, India)

Corresponding Author: More S.D.

---

**Abstract:** Automotive propeller shaft is a very important component of vehicle. It is used for power transmission from gear box to differential. Conventional steel propeller shafts are usually manufactured in two pieces to increase the fundamental bending natural frequency. But the two-piece steel propeller shaft involves three universal joints, an intermediary thrust bearing and a supporting bracket in its assemblage, which increases the total weight of the vehicle. The overall objective of this project is to design and analyze a composite propeller shaft for power transmission. Substituting composite structures for conventional metallic structures has many advantages because of higher specific stiffness and strength of composite materials. This work deals with the design of propeller shaft for "MAHINDRA LOAD KING" considering the torque capacity, shear stress & critical rpm requirement. In this work Glass/Epoxy is used as composite material for replacement of conventional two-piece steel propeller shafts. The design parameters were optimized with the objective of minimizing the weight of composite propeller shaft.

**Keywords:** Ansys, Composite Material, Propeller Shaft, Optimization.

---

Date of Submission: 18-04-2018

Date of acceptance: 07-05-2018

---

### I. Introduction

Rapid technological advances in engineering design field result in finding the alternate solution for the conventional materials. The design engineers brought to a point to finding the materials which are more reliable than conventional materials. Researchers and designers are constantly looking for the solutions to provide stronger and durable materials which will answer the needs of fellow engineers. The advanced composite materials such as Graphite, Carbon, Kevlar and Glass with suitable resins are widely used because of their high specific strength (strength/density) and high specific modulus (modulus/density). Advanced composite materials seem ideally suited for long, propeller shaft applications. Their elastic properties can be tailored to increase the torque they can carry as well as the rotational speed at which they operate. Propeller shafts are used in automotive, aircraft and aerospace applications. The automotive industry is exploring composite material technology for structural components construction in order to obtain the reduction of the weight without decrease in vehicle quality and reliability. It is known that energy conservation is one of the most important objectives in vehicle design and reduction of weight is one of the most effective measures to obtain this result. Actually, there is almost a direct proportionality between the weight of a vehicle and its fuel consumption, particularly in city driving.

### II. Composite Material

Composite consist of two or more material phase that are combine to produce a material that has superior properties to these of its individual constituent. Technologically the most important composite are those in which the dispersed phase is in the form of fiber. The composite materials can be classified on the basis of micro structures, multi phases, reinforcements, manner of packing of fibers layered compositions, method of compositions, matrix system, processing methods, etc. [1]

Composite materials can be classified as:

- 1) Polymer Matrix Composites.
- 2) Metal Matrix Composites.
- 3) Ceramic Composites.

The fibers are either long or short. Long and continuous fibers are easy to orient and process, where as short fibers cannot be controlled fully for proper orientation. The principal fibers in commercial use are various types of glass, carbon, graphite and Kevlar. All these fibers are incorporated in matrix form either in continuous length or in discontinuous length.

**Table No.1:** Properties of Steel – Glass / Epoxy material.

Mechanical Properties	Symbol	Units	Steel	Glass/Epoxy
Young's Modulus	E	GPa	207	210
Shear Modulus	G	Gpa	80	70
Poisson's Ratio	M	-	0.3	0.3
Density	P	Kg/m <sup>3</sup>	7860	1600
Yield Strength	Sy	MPa	370	420

**2.1 Advantages of composite materials over conventional materials**

1. High strength to weight ratio.
2. High stiffness to weight ratio.
3. High impact resistance.
4. Better fatigue resistance.
5. Improved corrosion resistance.
6. Good thermal conductivity.
7. High damping capacity.
8. Low coefficient of thermal expansion.

**III. Specification Of The Problem**

Vehicle weight reduction saves energy, minimizes brake and tire wear and cuts down emissions. Weight reduction of vehicles is directly linked to lower CO<sub>2</sub> emissions and improved fuel economy. The benefits of even modest vehicle weight reduction are significant. Replacing steel propeller shaft of vehicle with composite propeller shaft will help reducing weight of vehicle. The combustion of fossil fuels such as gasoline and diesel to transport people and goods is the fourth largest source of CO<sub>2</sub> emissions, accounting for about 12.9 % of total CO<sub>2</sub>emissions in India according to study published in 2008. CO<sub>2</sub>emission by human activities is one of the major reasons for excessive greenhouse gases in earth's environment, which is causing global warming. To reduce CO<sub>2</sub> emission due to transportation our focus should be on increasing fuel efficiency of the vehicle used for transportation. One of the ways of achieving it is reducing the weight of the vehicle. Our focus will be on reducing the weight of the propeller shaft by finding alternative light weight material for it which will contribute in reduction of weight of the vehicle eventually.

**IV. Methodology**

The typical working steps that will be involved in the proposed work are as follows:

- Detailed study and understanding of working of propeller shafts and design loads it will have to withstand during its working life.
- Designing appropriate conventional steel shaft by using proper design methods and considerations.
- Modeling the propeller shaft assembly with universal coupling using CAD tool.
- Performing Static analysis and validate the final steel propeller shaft design.
- Designing alternate options for conventional steel shaft design using composite materials.
- Performing static analysis on alternate designs of composite propeller shafts.
- Selection of the best suited option from the alternate designs by comparing analytical results.

**V. Design Of Steel Propeller Shaft**

The vehicle for which we are designing the propeller shaft is Mahindra Load King. Design of Experiments is performed to find out optimum shaft design using Taguchi matrix.

**Table No.2:** Design Parameters

Parameter of Shaft	Symbol	Units	Value
Outer Diameter	D0	mm	72
Inner Diameter	Di	mm	65.56
Length Of the Shaft	L	mm	1426
Thickness of the Shaft	T	mm	3.22
Load on the Shaft	Mt	N-m	1260
Di/D0	C	-	0.91

**5.1Maximum allowable shear stress,**

Shear Strength (Ssy) = 0.3 Syt

Ssy = 0.3 x 370 N/mm<sup>2</sup> (Ssy = 111 N/mm<sup>2</sup>)

Now, we will cross check the selected dimensions for torque transmission in the equation of torsion,

$$\tau = \frac{2 \times 16 \cdot M_t}{\pi D_o^3 (1 - c^4)}$$

$$\tau = \frac{2 \times 16 \times 1260 \times 10^3}{\pi \times D_o^3 (1 - c^4)}$$

$$\tau = \frac{40.32 \times 10^6}{\pi \times 72^3 \times (1 - 0.91^4)}$$

( $\tau = 109.42 \text{ N/mm}^2$ )

The maximum shear stress is 109.42 N/mm<sup>2</sup>, which is within the acceptable limit. Therefore the design of the shaft is safe.

**5.2 Torsional Buckling Capacity of Steel Shaft,**

$$T_{\text{buckling}} = \frac{\pi \times \sqrt{2} \times E}{3 \times (1 - \vartheta^2)^{0.75}} \times \sqrt{(r_{\text{avg}} \times T^5)}$$

$$T_{\text{buckling}} = \frac{3.147 \times \sqrt{2} \times 210 \text{ E}3}{3 \times (1 - 0.3^2)^{0.75}} \times \sqrt{(34.4 \times 3.2^5)}$$

T<sub>buckling</sub> = 35862126.11 N-mm

Therefore, (T<sub>buckling</sub> = 35862.13 Nm)

**5.3 Torsional Rigidity of Steel Shaft,**

$$\theta = \frac{L \times T}{J \times G}$$

Where,  $J = \frac{\pi \cdot D_o^4 (1 - c^4)}{32}$

$$\frac{72 \text{ E}3 \times \theta}{1426} = \frac{1260000}{8.29 \text{ E}05}$$

$\theta = 0.0301 \text{ rad}$   
 $\theta = 1.72^\circ$

Therefore, angle of twist per meter is given by,  $\theta = \frac{1.72}{1.426}$  ( $\theta = 1.20^\circ/\text{m}$ )

Angle of twist is 1.20 degrees per meter which is well within the acceptance criteria of maximum angle of twist for transmission shafts. Hence, the design is safe.

**5.4 First Natural Frequency of Steel Shaft,**

Natural Frequency (f<sub>1</sub>) of the shaft according to Rayleigh-Ritz is given as,

$$f_1 = \frac{1}{2\pi} \times \sqrt{\frac{g}{\delta_{st}}} \text{ Hz/rps}$$

Critical speed of the shaft can be obtained by multiplying the natural frequency by number of seconds in minute which is 60. Therefore critical speed in rpm can be given by,

$$N_s = \frac{30}{\pi} \times \sqrt{\frac{g}{\delta_{st}}}$$

We know from the deflection formulae for simply supported beam loaded with uniformly distributed load as,

$$\delta_{st} = \frac{5 \times W \times L^3}{384 \times E \times I}$$

The Area moment of inertia (I) is given by the formula,

$$I = \frac{\pi \times (D_o^4 - D_i^4)}{64}$$

$$I = \frac{\pi \times (72^4 - 65.6^4)}{64}$$

(I = 410122.6 mm<sup>4</sup>)

Mass of steel propeller shaft,

$$m = \rho A L = \rho \times \frac{\pi}{4} \times (D_o^2 - D_i^2) \times L$$

$$= 7860 \times 3.14/4 \times (72^2 - 65.56^2) \times 1426 \text{ [m = 7.5 Kg]}$$

Substituting values of W, I and L in the equation of static deflection we get

$$\delta = \frac{5 \times 7.5 \times 1426^3}{384 \times 2.1 \text{ E}5 \times 410122.6}$$

( $\delta_{st} = 0.00329 \text{ mm} = 0.00000329 \text{ m}$ )

Now substituting value of deflection in the equation of critical speed and natural frequency we get,

$$N_s = \frac{30}{\pi} \times \sqrt{\frac{9.81}{0.00000329}}$$

$$N_s = 16494.65 \text{ rpm}$$

$$f_1 = \frac{N_s}{60}$$

$$(f_1 = 274.92 \text{ Hz})$$

### VI. Design Of Composite Propeller Shaft

Similar to steel shaft all the calculations also performed on the GFRP material which is proposed as the alternative material for the steel, and following design table is obtained.

**Table No. 3.** Properties of material

Sr. No	Properties of Material	Glass Fiber
1.	Tensile Modulus along X-direction (MPa)	34000
2.	Tensile Modulus along Y-direction (MPa)	6530
3.	Tensile Modulus along Z-direction (MPa)	6530
4.	Compressive Strength of material (MPa)	450
5.	Poisson's ratio	0.217
6.	Mass Density of the material (g/cm <sup>3</sup> )	1.4

#### 6.1 Diameter of Solid Composite Propeller Shaft,

$$T = \pi/16 \tau D^3$$

$$1.260 \times 10^6 = \pi/16 \times 50 \times D^3 \quad (D=59.78=60\text{mm})$$

#### 6.2 Mass of Composite Propeller Shaft,

$$m = \rho AL = 1400 \times 3.14/4 \times 60^2 \times 1426 \quad (m=5.6 \text{ Kg})$$

### VII. Design Analysis

Finite element analysis is a computer based analysis technique for calculating the strength and behavior of structures. In the FEM the structure is represented as finite elements. These elements are joined at particular points which are called as nodes. The FEA is used to calculate the deflection, stresses, strains temperature, buckling behavior of the member.

In our project FEA is carried out by using the ANSYS 16.2. Initially we don't know the displacement and other quantities like strains, stresses which are then calculated from nodal displacement.

#### 7.1 Static Analysis

A static analysis is used to determine the displacements, stresses, strains and forces in structures or components caused by loads that do not induce significant inertia and damping effects. A static analysis can however include steady inertia loads such as gravity, spinning and time varying loads. In static analysis loading and response conditions are assumed, that is the loads and the structure responses are assumed to vary slowly with respect to time. The kinds of loading that can be applied in static analysis includes, Externally applied forces, moments and pressures Steady state inertial forces such as gravity and spinning Imposed non-zero displacements. If the stress values obtained in this analysis crosses the allowable values it will result in the failure of the structure in the static condition itself. To avoid such a failure, this analysis is necessary.

#### 7.2 Meshing

We have selected area mesh for the meshing with the element size of 4mm, which will provide us fine meshing. We have selected quadrilateral mesh element for accurate and uniform meshing of component. The meshing is the method in which the geometry is divided in small number of elements. This meshing of propeller shaft is as shown in below fig.

**Fig.1-Finite Element model of steel/GFRP Propeller Shaft**

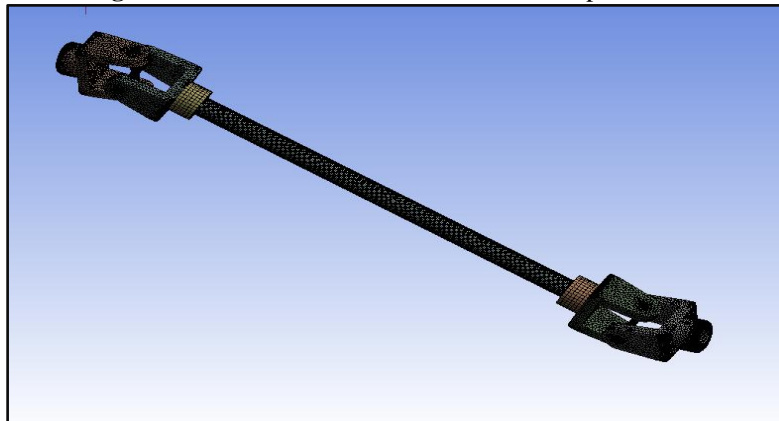

### 7.3 Selection of element type

SHELL181 may be used for layered applications of a structural shell model as shown in Figure SHELL181 allows up to 250 layers. The element has six degrees of freedom at each node: translations in the nodal x, y, and z directions and rotations about the nodal x, y, and z-axes. Shell 181 element type provides us to give the different material properties in X, Y and Z directions.

### 7.4 Torsional analysis

The boundary condition for the torsional analysis of drive shaft are given as the one end is constrained with zero displacement in the both linear and rotational. At the other end of shaft torque is applied.

Fig.2-Boundary Conditions for the torsional analysis

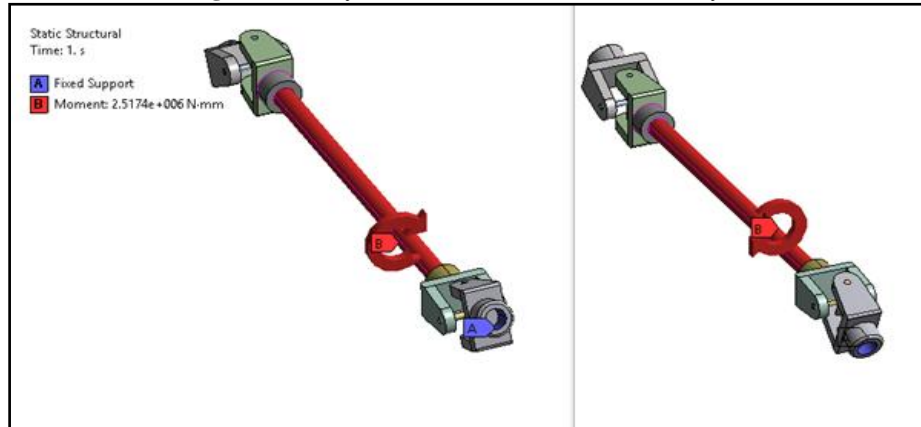

### 7.5 Modal analysis

When an elastic system free from external forces can be disturbed from its equilibrium position and vibrates under the influence of inherent forces and is said to be in the state of free vibration. It will vibrate at its natural frequency and its amplitude will gradually become smaller with time due to energy being dissipated by motion. The main parameters of interest in free vibration are natural frequency and the amplitude. The natural frequencies and the mode shapes are important parameters in the design of a structure for dynamic loading conditions. Modal analysis is used to determine the vibration characteristics such as natural frequencies and mode shapes of a structure or a machine component while it is being designed.

Modal analysis is used to determine the natural frequencies and mode shapes of a structure or a machine component. The rotational speed is limited by lateral stability considerations. Most designs are sub critical, i.e. rotational speed must be lower than the first natural bending frequency of the shaft. The natural frequency depends on the diameter of the shaft, thickness of the hollow shaft, specific stiffness and the length.

### 7.6 Buckling analysis

Buckling analysis is a technique used to determine buckling loads (critical loads) at which a structure becomes unstable, and buckled mode shapes. For thin walled shafts, the failure mode under an applied torque is torsional buckling rather than material failure. For a realistic driveshaft system, improved lateral stability characteristics must be achieved together with improved torque carrying capabilities.

## VIII. Findings Of Finite Element Analysis

### 8.1 Steel Shaft

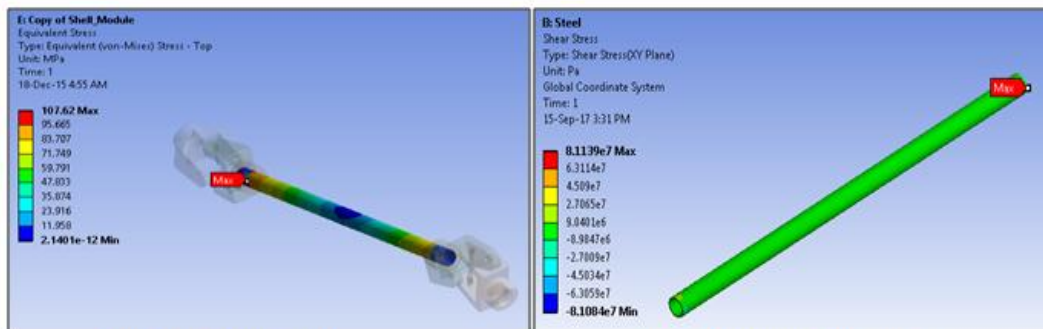

Fig.3-Equivalent Stresses

Fig.4-Maximum Shear Stresses

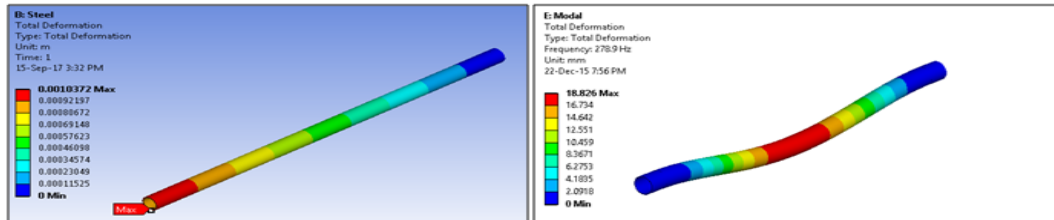

Fig.5-Total Deformation

Fig.6-Mode shape Plot for first natural frequency

## 8.2 GFRP Shaft

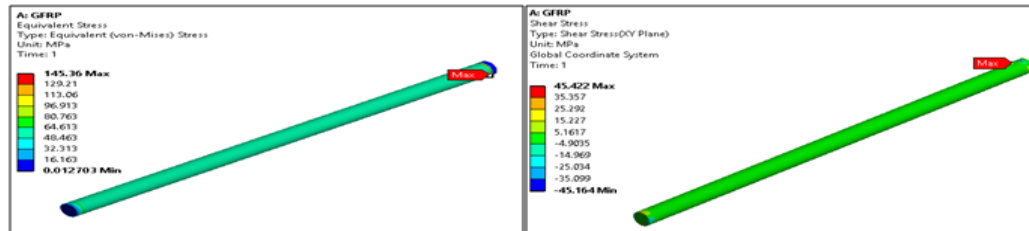

Fig.7-Equivalent Stresses

Fig.8-Maximum Shear Stresses

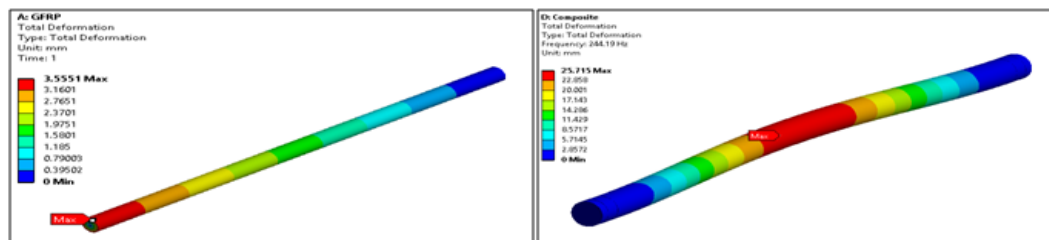

Fig.9-Total Deformation

Fig.10-Mode shape Plot for first natural frequency

## IX. Conclusion

- We have calculated 72 mm as outer diameter of the steel shaft and 65.6 mm which passes the acceptance criteria in FEA chapter.
- The finite element analysis is used in this work to predict the deformation of shaft.
- Composite shaft made up of GFRP material can be used to replace the conventional steel shaft in the given application successfully.
- Weight of the shaft is reduced by 28 % when composite shaft is used instead of conventional hollow steel shaft as propeller shaft of the given vehicle is observed.
- Hence GFR Psolid composite propeller shaft has been proposed to design to replace the two piece conventional steel propeller shaft of an automobile.

The FEA analysis is done to validate the analytical calculations of the work.

The results of the work are encouraging and suggesting to replacement of conventional propeller shaft by composite shaft has an added advantage.

The next phase of work consists of Different ply angle combinations can be tried in the FEA while designing the shaft of composite material and effect on the natural frequency and the deflection of the shaft can be studied.

## References

- [1]. John. W.et. al. Engineers Guide to Composite Materials, American Society for Metals, 1986.
- [2]. "Design and optimization of drive shaft with composite materials", R. P. Kumar Rompicharla, Dr. K. Rambabu Sir C.R.R college of Engineering Department of Mechanical Eluru, India, International Journal of Engineering Research & Technology (IJERT) Vol. 1 Issue 7, September - 2012 ISSN: 2278-0181
- [3]. "Review of Design of Hybrid Aluminum/ Composite Drive Shaft for Automobile", Bhushan K. Suryawanshi, Prajitsen G. Damle, International Journal of Innovative Technology and Exploring Engineering (IJITEE), March 2013.
- [4]. "Design and manufacture of an automotive hybrid aluminum/composite drive shaft" by Dai Gil Lee\*, Hak Sung Kim, Jong Woon Kim and Jin Kook Kim Korea advanced institute of science and technology, south Korea.
- [5]. "Developing a hybrid, carbon/glass fiber-reinforced, epoxy composite automotive drive shaft" by A.R. Abu Talib, Aidy Ali\*, Mohamed A. Badie, NurAzidaCheLah, and A.F. Golestaneh, University Putra, Selangor, Malaysia.
- [6]. "Dynamic analysis of a rotating composite shaft" by R. Sino, T.N. Baranger\*, E. Chatelet and G. Jacquet Laboratoire de Mecanique, University de Lyon, Villeurbanne, France.
- [7]. "An investigation into hybrid carbon/glass fiber reinforced epoxy composite automotive drive shaft" by M.A. Badie. Mahdi\* and A.M.S. Hamouda Mechanical and Industrial engineering department, college of engineering, Qatar University, Doha, Qatar.
- [8]. "Design of composite drive shaft and its coupling for automotive application" by M.R. Khoshrovan, A. Paykan.

- [9]. “Design of Automobile Driveshaft using Carbon/Epoxy and Kevlar/Epoxy Composites” by R. SrinivasaMoorthy, YonasMitiku& K. Sridhar School of Mechanical and Industrial Engineering, IoT, Bahir Dar University, Bahir Dar, Ethiopia.
- [10]. “Design and Analysis of Composite/Hybrid Drive Shaft for Automotives “by Parshuram D1, Sunil Mangsetty2. Pda College of Engineering Gulbarga.

More S.D. “Design And Optimization Of Composite Propeller Shaft .” IOSR Journal of Mechanical and Civil Engineering (IOSR-JMCE) , vol. 15, no. 2, 2018, pp. 83-89