

Development Of A Hybridized Fuzzy Logic And Transfer Function-Based Model For Intelligent Solar Tracking

B. Uebari, D.O. Dike, L.O. Uzoechi, S. O. Okozi, K. T. Ezirim & I. F. Ezebili
Department Of Electrical And Electronic Engineering, Federal University Of Technology Owerri, Nigeria
Department Of Mechatronics Engineering, Federal University Owerri, Nigeria.

Abstract

This paper presents the development and analysis of a solar tracking system using a transfer function model and Fuzzy Logic Controller (FLC). The study aims to optimize the performance of solar panels by accurately tracking the sun's position throughout the day. The transfer function model of the solar tracker is derived using physical and mathematical principles, considering the electrical and mechanical aspects of the DC motors used as actuators. The model is then implemented in MATLAB/Simulink for simulation and analysis. The FLC is designed to control the solar tracker's movement based on the error between the sun's angle and the panel's angle. The FLC uses predefined membership functions and fuzzy rules to determine the necessary panel adjustments. The performance of the FLC-based solar tracking system is compared with a fixed-axis tracking system. The results demonstrate that the FLC-based system consistently outperforms the fixed-axis system, with an average power output gain of 105.85% across different hours of the day. The FLC-based system shows significant improvements in energy capture, particularly during early morning and late evening hours when sun angles are less favourable. The study highlights the effectiveness of intelligent control systems in enhancing solar energy harvesting and validates the potential of FLC in optimizing the performance of solar tracking systems.

Keywords: *Fuzzy Logic controller, solar tracking. Transfer function model.*

Date of Submission: 22-05-2025

Date of Acceptance: 02-06-2025

I. Introduction

The growing global demand for sustainable and environmentally friendly energy sources has positioned solar energy as a leading candidate in the transition to renewable power systems. However, the efficiency of photovoltaic (PV) systems remains significantly influenced by their ability to accurately track the sun's position throughout the day. Traditional fixed-axis solar panels, while simple and cost-effective, fail to capture the maximum possible irradiance, particularly during early morning and late afternoon hours (Latha et al., 2019; Morega & Bejan, 2005).

To address this limitation, solar tracking technologies have evolved, with intelligent control systems emerging as a promising solution for dynamic orientation. Among these, Fuzzy Logic Controllers (FLCs) have gained traction due to their capability to manage non-linearities and system uncertainties without requiring precise mathematical models (Bandijah et al., 2021; Katkade, 2021). FLCs mimic human decision-making using linguistic rules and are particularly effective in environments with imprecise or noisy data—common in real-world solar tracking scenarios.

In parallel, the use of transfer function modeling, a classical technique in control systems engineering, enables accurate representation of system dynamics through linear time-invariant equations. This approach allows for comprehensive simulation and analysis of the system's response to varying input conditions. Integrating this technique with fuzzy logic control creates a powerful framework for optimizing solar panel orientation (Ndinechi et al., 2009; Motlatsi et al., 2020).

This study presents the development of an intelligent dual-axis solar tracking system based on a transfer function model of the tracking mechanism and a Fuzzy Logic Controller. The DC motors driving the system are modeled using physical principles, accounting for electrical and mechanical properties, and the overall system is simulated in MATLAB/Simulink. Comparative analysis with fixed-axis systems demonstrates that the proposed intelligent tracker significantly improves energy harvesting.

The quest for improved solar energy utilization has led to substantial research in solar tracking systems, particularly those that incorporate intelligent control strategies. Solar tracking is vital to ensure that photovoltaic (PV) panels maintain an optimal angle relative to the sun throughout the day, thereby maximizing incident irradiance and power output (Latha et al., 2019). Fixed-axis systems, though economical, suffer from efficiency limitations due to their inability to follow the sun's movement, especially during off-peak hours such as early mornings and late evenings (Ahmed, 2009).

To overcome these limitations, researchers have explored various tracking mechanisms, including single-axis and dual-axis trackers. Prodhan et al. (2016) evaluated the performance of a low-cost single-axis solar tracker and found that even basic tracking significantly increased energy capture compared to static systems. However, dual-axis trackers, capable of adjusting in both azimuth and elevation angles, have proven to be more effective in maintaining perpendicularity to sunlight, thus offering superior energy yield.

Traditional control systems for solar trackers include open-loop and closed-loop controllers, which often rely on sensors or predefined algorithms. Recent advancements, however, have seen a shift towards intelligent control methods such as fuzzy logic, neural networks, and hybrid systems. Fuzzy Logic Controllers (FLCs), in particular, have garnered attention for their ability to handle nonlinearities and imprecision in environmental data. Bandijah et al. (2021) proposed a sensorless fuzzy logic-based tracking system and demonstrated its ability to deliver precise panel orientation without requiring extensive sensor data, reducing system complexity and cost.

Katkade (2021) developed an intelligent solar tracking system using fuzzy logic and servo motors. The study highlighted the advantages of using linguistic control rules over conventional control algorithms, especially in dynamically changing solar conditions. Similarly, Waleed et al. (2015) designed and implemented a dual-axis tracker with smart monitoring and found that intelligent controllers significantly enhanced tracking precision and power output.

While fuzzy logic enhances decision-making, the performance of solar tracking systems also heavily depends on accurate system modeling. Transfer function models provide a mathematical framework for analyzing and simulating the behavior of control systems. These models simplify complex dynamic systems into input-output relationships that are crucial for controller design and system stability analysis. Ndinechi et al. (2009) developed a microcontroller-based solar tracker with a focus on practical implementation but acknowledged the importance of incorporating accurate system dynamics for better control performance.

Motlatsi et al. (2020) compared different tracking algorithms and emphasized the need for adaptive control strategies that consider the nonlinear behavior of solar trackers and environmental variations. The integration of transfer function modeling with fuzzy logic, as presented in the current study, bridges the gap between physical system representation and intelligent control, offering a robust framework for real-time solar panel orientation.

In summary, previous studies have laid a strong foundation for intelligent solar tracking using fuzzy logic. However, few have combined this approach with system-level modeling using transfer functions. This paper builds upon existing literature by presenting a unified model that incorporates the mechanical and electrical dynamics of the tracking system and applies fuzzy logic control for intelligent tracking—resulting in enhanced efficiency, especially during low irradiance periods. Furthermore, the application of this Transfer Function Model and Fuzzy Logic Controller (FLC), innovation will reduce the concerns over high absorptivity and low emissivity of Silicon PV's during early mornings and late evenings as low-emissivity coatings like silver, ITO (Indium Tin Oxide), and other thin films are usually deployed to the glass cover of solar panels to reduce thermal radiation loss.

This innovation will reliably sustain the existing cut throat competition between Silicon-made PVs and emerging solar panel technologies like the Perovskite Solar Cells (PSCs) most recently developed by Japan. PSCs are lightweight, flexible, and efficient, and are ideal for urban settings where space is limited and conventional solar farms are really impractical.

PSCs high efficiency rate cannot go unnoticed as some models attain about 43% efficiency, compared to the about 29% of Silicon Undoubtedly, with the Transfer Function Model and Fuzzy Logic Controller (FLC), the Silicon PV's efficiency will be closing up with those of the Perovskite Solar Cells thus sustaining its position as a viable competitor Japan Energy Summit & Exhibition Conference (2025)

II. Basic Terminologies And Definitions

Transfer Function: A transfer function is a mathematical representation (typically in the Laplace domain) that models the input-output relationship of a linear time-invariant system. In your study, it is used to represent the dynamics of the DC motor used in the solar tracking system.

Fuzzy Logic Controller (FLC): A control system based on fuzzy logic that mimics human reasoning. It operates using linguistic rules rather than precise numerical equations, making it effective in dealing with uncertainty and non-linearity in systems like solar trackers.

Solar Tracking System: A mechanism that orients solar panels toward the sun to maximize energy capture. Dual-axis solar trackers adjust both azimuth and elevation angles to maintain optimal alignment with sunlight throughout the day.

Photovoltaic (PV) Panel: A device that converts sunlight directly into electrical energy using the photovoltaic effect. Its performance is highly dependent on its orientation to the sun.

DC Motor: A Direct Current motor used as an actuator in the solar tracking system to drive the rotation of solar panels along specified axes. Its behavior is modeled electrically and mechanically in your study.

Defuzzification: The process of converting fuzzy output values from the FLC into a precise control action (crisp output) to drive the motors and adjust the solar panel's position.

Simulation (in MATLAB/Simulink): The process of modeling and analyzing the behavior of a system in a virtual environment before physical implementation. In this study, simulation validates the effectiveness of the proposed control system.

III. Methods

Transfer Function Model

The mathematical model of a control system is a set of mathematical equations used for the analysis and design of the control system. It aids in designing the input and output of the system which is used to develop transfer function model of the solar tracking system. The following steps discuss the development of transfer function modeling of a solar system.

The actuator chosen for the tracker is the DC motors. The motor rotates the solar panel system around the East/West and North/South axes. In order to develop a model for the motor, the electrical and mechanical aspects are considered. Considering Figure 3.1, and specifying the angular twist of the shaft as θ , the differential equations for the motor can be obtained.

Applying Kirchhoff's current and voltage laws, the electrical system equations are thus expressed as

$$(1)$$

$$(2)$$

Then,

Where, V_{IN} is the input voltage, K_A is the amplifier voltage gain, V_M is motor input voltage, R_A is motor armature coil resistance, L_A is motor armature coil inductance, $i_A(t)$ is motor armature coil current, V_B is motor back EMF, K_T is motor torque constant, K_B is motor back EMF constant, J_L is motor shaft angular velocity, and θ is motor shaft position.

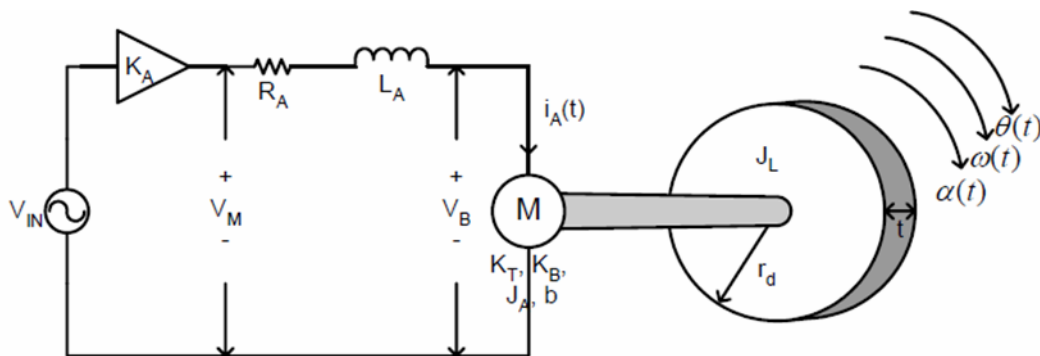

Figure 1: DC motor representation

The mechanical system includes the following differential equations

$$(4)$$

where, K_T is motor torque constant, α is the motor shaft angular acceleration, and J_L is the total inertia acting on the shaft which include the motor armature inertia, gear train inertia, and the solar panels inertia.

Substituting equations 1 and 3 in 2, we obtain

$$(5)$$

Also, substituting equation 4 into 5, we have

$$(6)$$

Applying Laplace transforms to equations 6 and 7,

$$(7)$$

$$(8)$$

$$(9)$$

Making subject of the formula in equation 9 and substituting the same in equation 8, the final transfer function for the solar tracker drive mechanism is expressed as:

$$(10)$$

The state space model is:

$$(11)$$

Solar Tracker System

The solar tracking system model developed in equation 10 is a continuous-time transfer function model which was finally modeled in Simulink. The system constitutes two DC permanent magnet motors for controlling the direction of the panel in both horizontal and vertical direction. To realize this continuous-time transfer function model, the following parameters were inserted into equation 10 and the result obtained is expressed in equation 12.

- KT = 0.1112; Torque constant (Nm/A)
- KA = 1.38; Amplifier gain (V/m)
- JT = 87.6855; Total moment of inertia (kg*m²)
- LA = 0.13; Armature inductance (H)
- RA = 0.5; Armature resistance (Ohms)
- b = 0.001; Viscous friction coefficient (Nm/KRPM)
- KB = 0.1098; Back EMF constant(V)

$$(12)$$

The input to the tracker mechanism is a 48V voltage to energize the two PMDC motors responsible for delivering required slew rate through gear mechanism, while the output is the angular position.

Implementation of Developed Model

The simulation of the smart solar tracking system was done using MATLAB/Simulink environment. The input to the tracker mechanism is a 48V voltage to energize the two PMDC motors responsible for delivering required slew rate through gear mechanism, while the output is the angular position. The tracker was simulated for 24 hours separately to assess its response and also determine how the Fuzzy Logic controller tracks the sun rays. Figure 2 shows the block diagram of the solar tracking system.

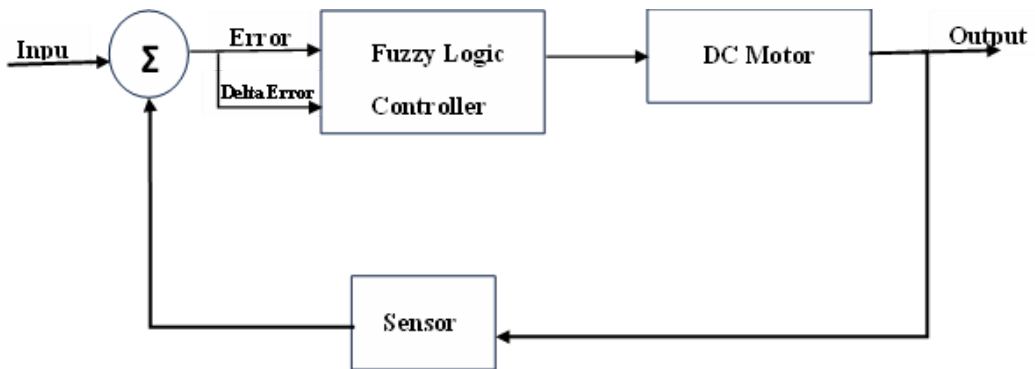

Figure 2: Block diagram of the solar tracking system.

Working operation of the device: The flowchart of Fuzzy Logic solar tracking system is shown in Figure 3.

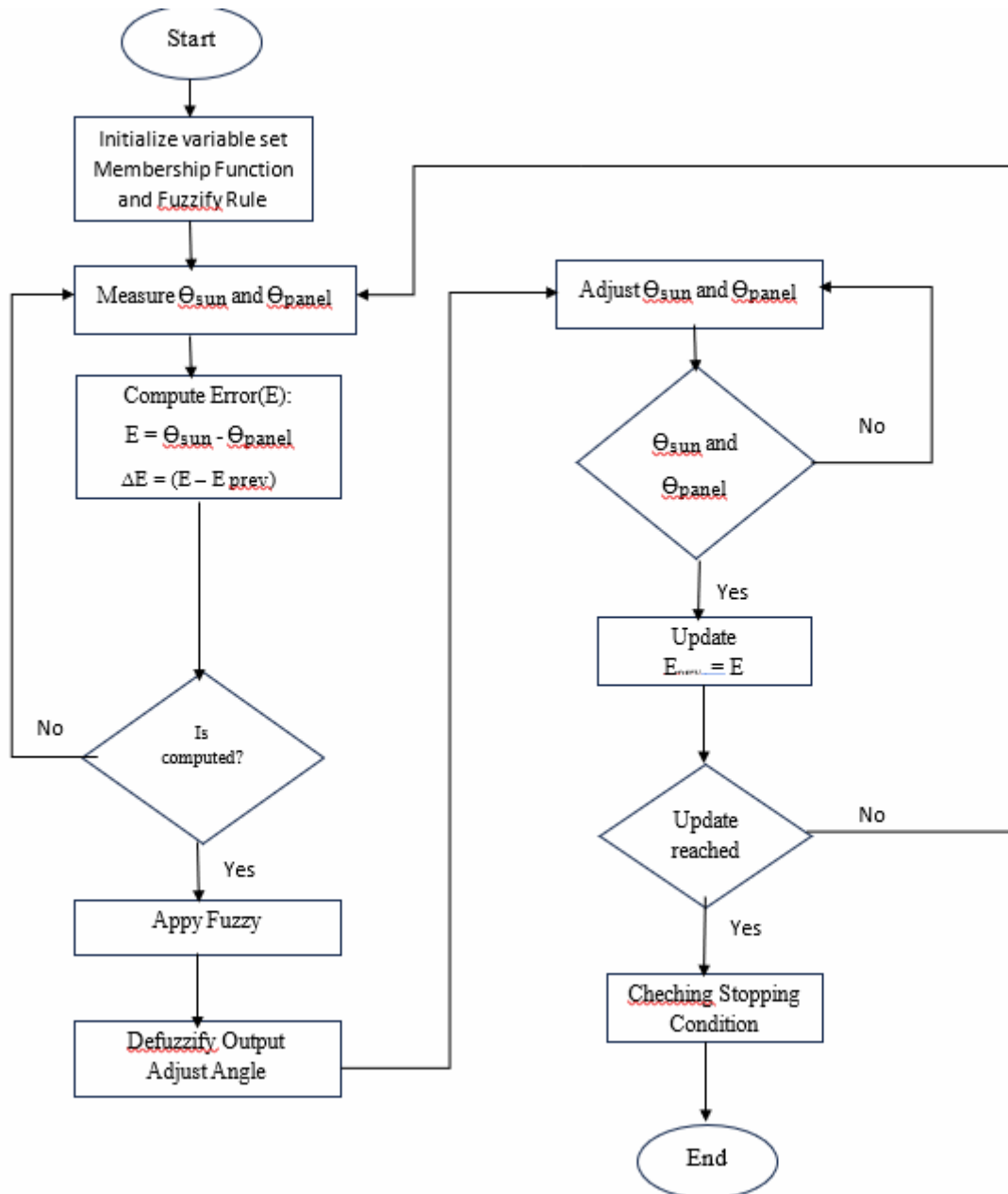

Figure 3 Fuzzy Logic Solar Tracking System flowchart

The fuzzy logic-based solar tracking system follows a step-by-step process to align the solar panel with the sun's position.

Start: The system initializes.

Initialize Input Membership Functions and Fuzzify Rules: Define fuzzy membership functions (for error and change in error). Establish the fuzzy rules for decision-making.

Measure θ_{sun} and θ_{panel} : θ_{sun} : The current angle of the sun. θ_{panel} : The angle of the solar panel.

Compute Error (E):

$E = \theta_{sun} - \theta_{panel}$ (difference between sun and panel angles). Compute change in error: $\Delta E = E - E_{prev}$

Check If Computation is Done: If error values are computed, proceed; otherwise, recompute.

Apply Fuzzy Logic:

Convert the numerical error into linguistic terms (e.g., "small," "medium," "large"). Apply predefined fuzzy rules to determine the necessary panel adjustment.

Defuzzify the Output and Adjust Angle: Convert fuzzy output into a crisp value to rotate the solar panel.

Adjust θ_{sun} and θ_{panel} : The panel moves accordingly.

Update $E_{prev} = E$: Update previous error value for future computations.

Check Stopping Condition: If alignment is achieved, the system stops. If not, the cycle repeats.

The final analogy in this thesis was to briefly compare the results of this different tracking system with the sole aim of finding which of them has a better performance given all the developed models. It is important to display the values of the solar panel generated current, voltages, insolation and power as illustrated in tables 1

IV. Results And Discussions

This section presents the results obtained from the simulation of the smart solar tracking system using MATLAB/Simulink

Table1: Power generated for different tracking systems

Time (Hours)	Fixed-Axis Tracking	Solar Tracking with FLC
6	7.333	19.456
10	40.005	60.632
12	43.025	85.178
14	43.025	87.950
16	27.33	62.568
18	16.75	30.637

Table 1 displays the power output, calculated as the product of current and voltage, for three solar tracking configurations: fixed-axis tracking and Fuzzy Logic Controller (FLC)-based tracking. The power values offer a comprehensive view of each system’s effectiveness in energy conversion under varying solar conditions throughout the day. At 6:00 hours, the fixed-axis tracking system produces the least power at 7.333 W, while the FLC yields 19.456 W. This early morning comparison demonstrates how intelligent controllers enhance energy capture even under low-light conditions. As solar irradiance intensifies by 10:00 hours, power generation increases across all systems. The fixed-axis system records 40.005 W, while the FLC system achieves a significantly higher value of 60.632 W,. This trend continues into midday, with peak power generation observed at 12:00 and 14:00 hours.

Notably, FLC (85.178 W and 87.950 W) systems, clearly outperforming the fixed-axis (43.025 W). The FLC system shows commendable performance, especially in the late afternoon. In contrast, the fixed-axis tracking system demonstrates the least efficiency due to its static nature and inability to adjust to the sun’s movement. The results clearly advocate for the implementation of intelligent tracking systems, particularly those using FLC, in photovoltaic applications to maximize daily energy yield and improve overall system performance. Figure 4 illustrates the summary of the Table 1, and shows that the designed solar tracking system with Fuzzy Logic controller performed better than a fixed axis system.

Table 1 and Figure 4 illustrate the power output of both the Fixed-Axis Tracking system and the Solar Tracking system integrated with a Fuzzy Logic Controller (FLC) at different hours of the day. A clear trend emerges showing that the FLC-based solar tracker consistently outperforms the fixed-axis system at all observed time points. Quantitatively, the percentage gain in power output using the FLC system ranges from 51.47% (at 10:00 hours) to as high as 165.30% (at 6:00 hours).

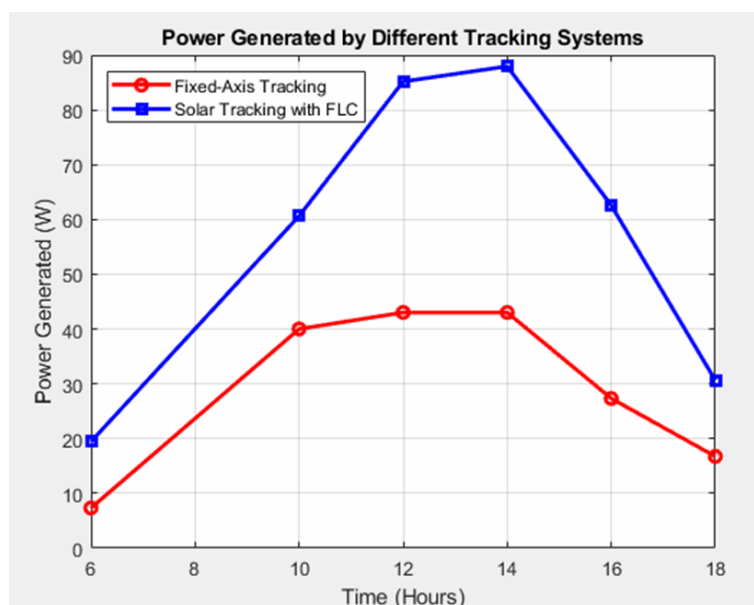

Figure 4: Comparison of solar panel generated power

The average percentage gain across all time intervals is approximately 105.85%, demonstrating that the smart tracking system more than doubles the power output compared to the traditional fixed setup. This substantial improvement can be attributed to the adaptive decision-making capability of the fuzzy controller, which ensures optimal panel orientation by responding to dynamic environmental conditions such as irradiance and sun position. The results validate the effectiveness of intelligent control systems in enhancing solar energy harvesting, especially during early morning and late evening hours when sun angles are less favorable.

The Fixed Controller, characterized by a natural frequency of 3 and a damping ratio of 0.3, exhibits a sluggish step response. This controller shows a relatively slow rise time and significant overshoot, which means it, takes longer to reach the steady-state value and often overshoots the desired set point before settling. The lower damping ratio contributes to noticeable oscillations before the system stabilizes. This behavior indicates that while the Fixed Controller is straightforward in design, it struggles with rapid stabilization and may not handle sudden changes or dynamic conditions effectively as shown in the Figure 5.

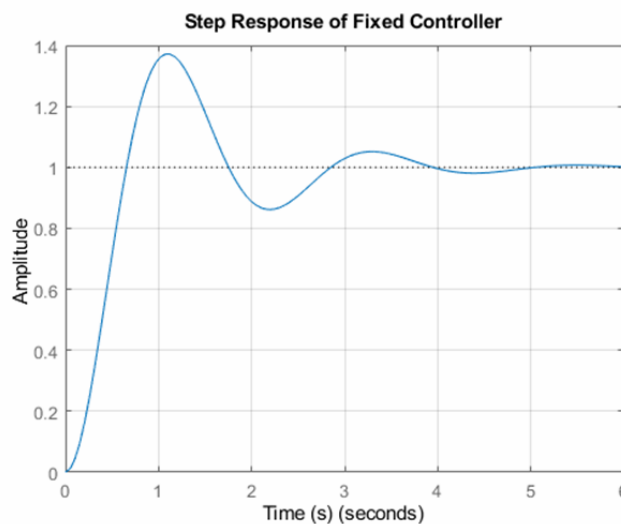

Figure 5: Variation of Step response of fixed controller

The Fuzzy Logic Controller, with a natural frequency of 4 and a damping ratio of 0.5, demonstrates a more responsive behavior compared to the Fixed Controller. It achieves a quicker rise time and moderate overshoot, reflecting its improved ability to handle sudden changes. The moderate damping ratio helps reduce oscillations and smooth out the response curve, leading to a more stable and efficient transition to the steady state. This improved performance is due to the Fuzzy Logic Controller's ability to adapt to varying conditions through its rule-based inference system, which provides better control over dynamic responses as shown in Figure 6.

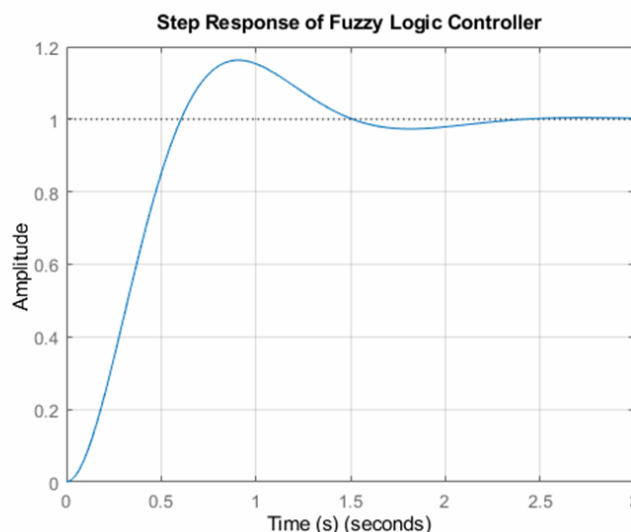

Figure 6: Fuzzy Logic Controllers

Table 2 provides a comparative analysis of the performance characteristics of various controllers, highlighting their respective strengths in terms of rising time, settling time, maximum overshoot, peak time, and steady-state error.

Table 2: Comparative analysis of the performance characteristics of various controllers

Controller	Fuzzy Logic Controller	Fixed Controller
Rising Time (s)	2	2.5
Settling Time (s)	3.2	4
Maximum Overshoot (%)	15	20
Peak Time (s)	2.6	3.2
Steady State Error (%)	1	1.5

The Fuzzy Logic Controller, with a rising time of 2 seconds and a settling time of 3.2 seconds, demonstrates a balanced response with a maximum overshoot of 15% and a steady-state error of 1%. This indicates it can manage sudden changes effectively while maintaining a reasonable level of overshoot and error.

V. Conclusion

This paper presents the development and analysis of a solar tracking system using a transfer function model and Fuzzy Logic Controller (FLC). The study aims to optimize solar panel performance by accurately tracking the sun's position throughout the day. The transfer function model is derived considering the electrical and mechanical aspects of the DC motors used as actuators.

The FLC controls the solar tracker's movement based on the error between the sun's angle and the panel's angle, using predefined membership functions and fuzzy rules. Simulation results demonstrate that the FLC-based system consistently outperforms the fixed-axis system, with an average power output gain of 105.85% across different hours of the day, particularly during early morning and late evening hours. The study highlights the effectiveness of intelligent control systems in enhancing solar energy harvesting and validates the potential of FLC in optimizing solar tracking system performance.

References

[1] Ahmed, R. (2009). *Solar Energy: An Effective Alternative In Developing Countries*. Renewable Energy Press.

[2] Bandijah, H., Abdullah, M. A., & Rosli, M. F. (2021). A Sensorless Closed-Loop Solar Tracking System Using Fuzzy Logic Controller. *International Journal Of Advanced Computer Science And Applications*, 12(6), 155–160. <https://doi.org/10.14569/IJACSA.2021.0120619>

[3] Japan Energy Summit & Exhibition Conference (2025). <https://www.googleadservices.com/pagead/aclk>

[4] Joseph, A. (1991). *Renewable Energy Systems In Europe: A Comparative Study*. Energy And Environment Publications.

[5] Katkade, S. (2021). Design Of Intelligent Controller For Solar Panel Tracking System Using Servo Motor. *International Journal Of Innovative Research In Science, Engineering And Technology*, 10(4), 1382–1387. <https://doi.org/10.15680/IJRSET.2021.1004074>

[6] Latha, A., Kumar, R., & Thomas, M. (2019). The Photovoltaic Effect And Solar Power Generation: A Review. *International Journal Of Scientific Research And Engineering Development*, 2(3), 512–518.

[7] Merigan, M. (1975). *The Early Development Of Photovoltaic Cells*. Solar Energy Foundation.

[8] Morega, A. M., & Bejan, A. (2005). Physics Of The Photovoltaic Effect In Semiconductors. *Renewable And Sustainable Energy Reviews*, 9(3), 347–357. <https://doi.org/10.1016/j.rser.2004.03.004>

[9] Motlatsi, T., Motsamai, M., & Mpho, P. (2020). Comparison Of Two Automatic Solar Tracking Algorithms For PV Systems. *Journal Of Solar Energy Engineering*, 142(5), 050902. <https://doi.org/10.1115/1.4046845>

[10] Ndinechi, E. N., Okoro, O. I., & Agu, M. U. (2009). Design And Construction Of A Microcontroller-Based Solar Tracking System. *Nigerian Journal Of Technology*, 28(2), 77–85.

[11] Nurhani, M., Rosli, N. M., & Harun, S. (2020). Arduino-Based Solar Tracker Using Light Dependent Resistors. *Indonesian Journal Of Electrical Engineering And Computer Science*, 18(2), 842–850. <https://doi.org/10.11591/ijeecs.v18.i2.pp842-850>

[12] Prodhan, S. M., Hasanuzzaman, M., & Rahim, N. A. (2016). Performance Evaluation Of A Low-Cost Single-Axis Solar Tracker. *Energy Procedia*, 100, 98–103. <https://doi.org/10.1016/j.egypro.2016.10.141>

[13] Waleed, A. A., Kamel, S., & Khaled, M. (2015). Design And Implementation Of A Dual-Axis Solar Tracking System With Smart Monitoring. *International Journal Of Engineering Research And Technology*, 4(8), 217–222.