

Experimental Design and Construction of an Enhanced Solar Battery Charger

Faithpraise, Fina¹, Basse, Donatus¹, Charles, Mfon¹, Osahon, Okoro², Udoh, Monday¹, Chatwin, Chris³

¹(Electronics and Computer Technology Unit, Department of Physics University of Calabar, 54000, Nigeria

²(Computer Science Department, University of Calabar, Calabar –Nigeria)

³(School of Engineering and Informatics, Department of Engineering and Design, University of Sussex, Brighton. United Kingdom

Abstract : A Solar Battery Charger circuit is designed, built and tested. It acts as a control circuit to monitor and regulate the process of charging several batteries ranging from 4 volts to 12 volts, using a photovoltaic (PV) solar panel as the input source for the battery charging process. The circuit is economical and can be easily constructed from discrete electronic components. The circuit operation is based on matching the solar panel terminal load voltage to the input terminal of the charging circuit and the appropriate number of battery cell units to be charged to the output circuit through the use of a current limited voltage regulator, allowing fast charging while limiting heat build-up and gassing and a rotary switch for easy selection of the appropriate voltage depending on the solar light intensity. Experimental results indicate that there is an increase of the overall charging current when fully charging an empty: mobile phone battery and a 6v rechargeable lamp for 4 hours using direct charging between 10.00am to 4.00pm. The success of this device will bridge the gap of power failure that often occur within the hours of the day between 10.00am to 4.00pm, especially in rural communities.

Keywords: Solar, battery, charger, circuit, monitor.

I. Introduction

The idea to harness the power of the sun to charge batteries has been known since France decided it needed an alternative source of energy in the 70's, [1]. Satellite technology has given clear pictures to designers about solar energy intensity exploration and distribution worldwide [2] [3]. Solar energy research emphasis over the past three decades has concentrated on solar energy direct heat production and solar energy electricity production.

In 19th century, scientists discovered that the silicon crystal is very good semiconductor that can be fabricated into solar cells and panels to produce electricity when placed in sunlight. [4] Analyses the technical progress of photovoltaic cells thereby predicting its future trend. The goal of our research is to design: (1) a universal battery charger that can use electric power supply as well as solar energy as its input source; (2) a system capable of charging varying voltages of batteries (small and large voltages) and (3) a system that is able to control the state of the charging to avoid overheating.

II. Related works

There are several research on the enhancement of solar energy technology and the efficiency of solar battery chargers among whom are [5] who analyses ways to increase the solar photovoltaic energy capture on sunny and cloudy days. [6] John constructed a 12 volts batteries charger using a solar panel of 12 volts, but his circuit does not have indicators to show when it is fully charged. [7] Worked on an automatic solar battery charger circuits that has the capacity to charge lead- acid batteries of 6v to 24volts but without a heat sink to absorb excess heat. [8]. Built a solar battery charger for 12 volts lead-acid batteries using components like the schoktty diode combined with a Field Effect Transistor (FET) and some passive components. The charger stops charging once the pre-set voltage has been reached and commences charging when the voltage has dropped off sufficiently. It uses less than 0.5mA when using TLC393 comparators, and burns less than 20mW of power in FETs when charging at 0.5A. [9]. Constructed an electronic control circuit for a 6v and 12volts solar battery charging circuit.[10] Used a solar panel of 12 volt and an Op-Amp as a shunt regulator to construct a 12 volt battery solar charger. [11] Implemented a solar panel of 12 volts with an LM 317T IC as a voltage regulator, and a schottky diode to prevent the discharging of the battery, a potentiometer for voltage adjustment, but added a 1N4007 diode to construct a solar battery charger for 6 volts lead acid battery. [12] Constructed a solar battery charger using a small solar panel of 3 volts or 6 volts and a perfect blocking diode (schottky diode 1N5817) to charge up some AA cells or AAA NiMH cells.

To enhance the design and performance of a solar battery charger, a current limited voltage regulator, which allowed fast charging while limiting heat build-up and gassing, was used to safely charge the battery. A heat sink to absorb the excess heat, a rotating switch to select different voltages for the battery specification to be charged and a LED as an indicator to show when the battery is fully charged has been incorporated into the design.

III. Design and construction methodology

As illustrated in [9] “the open circuit voltage of a solar panel varies exponentially with the intensity of solar radiation, reaching a limiting value. The cell voltage will normally assume the value of the battery terminal voltage, which has an approximately fixed quantity or value with an exception for a highly drained battery. It is common practice to design photovoltaic solar system for battery charging with the solar panel open circuit saturation voltage being 1.5 times the nominal emf of the battery to be charged. Even with such a design, a good deal of sun energy from morning, afternoon hours and cloudy weather may not be exploited properly due to the fact that the operating point will slip back into the exponential regions.

“In order to gain more insight into the problem let the solar panel be represented by a voltage source E , an internal resistance r , and a diode D . When the electromotive force E exceeds that of the battery to be charged E_0 , charging current i will flow as

$$ir = E - E_0 \tag{1}$$

The power stored in the battery will be $P = iE_0$.

The solar panel internal resistance r is equal to the open circuit voltage E divided by the short circuit current I_0 .

That is $r = \frac{E}{I_0}$

For a typical solar panel, this current will be proportional to the radiation fallout Ψ . Thus, $I_0 = K\Psi$, where K is a panel constant related to the charge conversion efficiency.

$$P = E_i - i^2r \tag{2}$$

For maximum power condition, we have

$$i = \frac{E}{2r} = \frac{I_0}{2} = \frac{K\Psi}{2} \tag{3}$$

For a particular fallout condition, it would be beneficial to try to adjust the charging current value in accordance with equation (3). This can be achieved through the adjustment of the electromotive force of the battery being charged.

Let us assume that we have a solar panel that has been designed to charge a battery consisting of N cells each has an electromotive force x under full radiation fallout condition.

Let us assume the electromotive force for the panel to be equal to $1.5N_x$.

Let assume that this panel is used to charge a smaller number of series cells $n < N$. The electromotive force solar fallout relation of a typical solar panel is usually of an exponential type. For such a case, equation (1) may be rewritten as

$$1.5N_x(1 - e^{-k\Psi}) - nx = ir \tag{4}$$

Where K is the conversion efficiency factor.

If one chooses to perform the charging process under the maximum power condition, the current i will be that given by equation (3). If we further assume that the panel open circuit voltage is approximately equal to $1.5N_x(1 - e^{-k\Psi})$

Such that

$$1.5N_x(1 - e^{-k\Psi}) - nx = \frac{K\Psi}{2} \frac{1.5N_x(1 - e^{-k\Psi})}{K\Psi} \tag{5}$$

This gives

$$n = \frac{3N}{4} (1 - e^{-k\Psi}) \tag{6}$$

(Equation (6)) gives the number of unit cells that can be charged under maximum power condition as a function of the solar radiation fallout.

3.1 Designed System Illustration

This designed system uses a two-step process to charge batteries such as Sealed Lead Acid (SLA) batteries namely; a current limited ‘fast’ mode followed by a constant voltage ‘float’ mode.

An on-board LED indicates when the charger is in ‘fast’ mode. When the LED goes out the battery is charged and the charger has switched to ‘float’ mode.

The best way to charge these batteries is with a current limited voltage regulator, allowing fast charging while limiting heat build-up and gassing. Sealed lead acid (SLA) batteries are made up of 2V (nominal) cells. Therefore a 12V battery has 6 cells.

The following parameters were used for this charger

- The charging current is approximately 0.1 times the battery capacity. So, a 10Ah battery should be charged with a 1A current ($10 \times 0.1 = 1$). This helps to ensure good battery life.
- The charging voltage is 2.45V per cell = 14.6V
- Float charging voltage is 2.30V per cell = 13.8V. The Float Charge Control (FCC) charges the battery at a constant voltage and also maintains a charged battery.
- This two-step battery charger works as follows:
- Charging starts at the maximum current limit. The battery terminal voltage will gradually increase until it reaches the regulator set voltage.
- As the battery becomes fully charged the current will start to decrease. When the charging current drops to around 140mA the regulator voltage would decrease to a safe float voltage at which the battery can be left on charge indefinitely.

From Fig. 1 below, the charging circuit derived its energy from a 12V /20watt 1.5A solar panel, which is a DC supply. The DC supply from the solar panel is passed through a low pass filter. The 470µF capacitor is necessary to ensure that the battery is charged with DC that is free from ripple. A 3-terminal regulator, REG1, sets the maximum battery charge voltage to 6.5V, 8V and 14.6V for a 4V, 6V and 12V batteries respectively. It operates as thus; the voltage between its output and adjust (ADJ) pin is fixed at 1.25V and this voltage is applied across the 120Ω resistor R2 (neglecting the small current drawn by the ADJ pin). The resulting 100µA through the 120Ω resistor flows through the 330R, 1K; resistor and series 500Ω trim pots to provide a voltage across them, effectively jacking up the regulator voltage. Trim pots are adjusted for an output voltage of 6.5V, 8V and 14.6V.

A 0.7Ω/5W wire wound resistor is used to monitor the charging current. The voltage developed across it is monitored by transistor Q2. When the voltage across the 0.7Ω resistor reaches 0.7V, corresponding to a charging current of 1A, the base voltage of Q2 reaches about 0.7V and it begins to conduct, pulling the ADJ pin of REG1 lower to reduce the output voltage of REG1. This limits the charging current to 1A. Transistor Q1 also monitors the voltage across the 470Ω resistor. Q1 turns on whenever the resistor voltage is above 0.7V to drive LED1 which is the charging indicator. So providing the charging current is more than or about 500mA, LED1 will light up. Once the 12V battery voltage reaches 13.8V, which is the floating charge voltage, the charging current drops to zero and the battery is effectively “on float”.

Diode D1 protects the regulator from damage in case the input is mistakenly short-circuited to ground while it is powered up. Without D1, the current will attempt to flow back from the output capacitor through the regulator to the short-circuited input that could damage the regulator. D1 becomes forward biased and conducts, effectively preventing any reverse current flow through REG1. D2 is also included to protect REG1. It does this by clamping the voltage between the ADJ terminal and the OUT and IN terminal in the event that one of the later is short-circuited to ground. When the input source to the charger is removed, the battery may drain back via the resistors across REG1. To stop this, a diode is added to the circuit to prevent the battery from discharging back to the charger if no power is present.

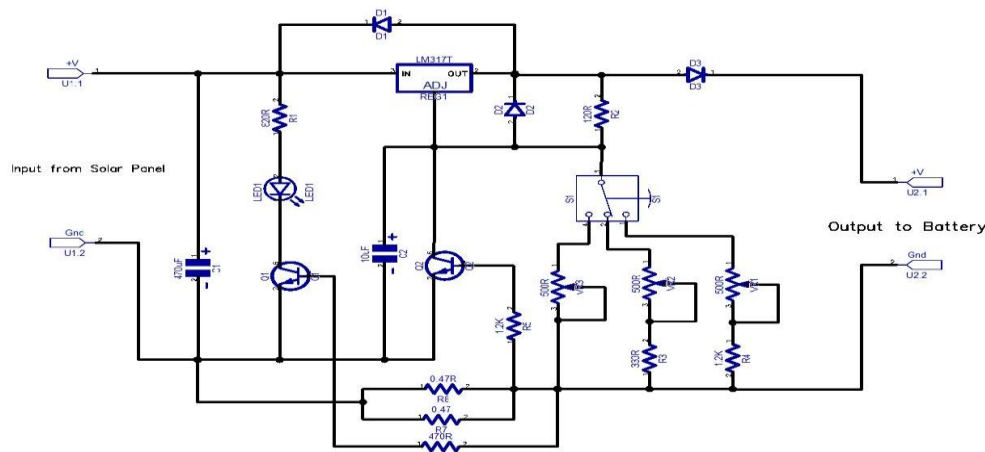

Figure 1. Solar battery charger circuit design view

3.2 Technical Specification

The solar panel has a rating of 20 Watt (12 volts). The charging circuit produces voltage outputs ranging from 4 volts to about 12 volts. The maximum power dissipation is about 10 watt. The drop-out voltage, which is also referred to as “maximum head voltage” depends upon the load current and the typical drop-out voltage for this circuit is about 2.75 volts (i.e. the input voltage must not exceed the output voltage by about 2.75 volts. A diode is selected to reduce this head voltage requirement (the voltage drop of the diode is about 0.7 volts at 1 Ampere). The maximum current produce by this circuit is 1A. It has a LED as an indicator. Also, the voltage regulation of this circuit is about $\pm 100\text{mV}$ and the battery discharges at about zero mA when there is no sunlight energy on the solar panel. In this design, power is limited because of the thermal resistance of the voltage regulating IC and its heat-sink. To keep the temperature below 125 degree Celsius, the power must be limited to about 10Watt. The voltage regulator internally has a temperature limiting circuit so that if it gets too hot, it shuts down automatically. When the battery is charging, the heat sink becomes warm. When completing the charging at maximum voltage, the heat-sink runs hot. This heat is because of excess power that is not needed in the process of charging the battery, see Appendix A.

IV. Result and discussion

Testing of this battery charging system is one of the paramount things to be completed before putting it into proper usage. In order to accomplish this, a digital multi-meter was used in the measurement of the circuit's input and output. Before connecting the panel to the circuit, its open circuit voltage was tested under low, normal and intense sunlight. The panel gave about 9V at low sunlight, about 13.6V at normal sunlight and about 18V with intense sunlight. The current produced by the panel was tested by short circuiting it with a load, it gave about 300mA under low sunlight, and about 1.5A under intense sunlight. The positive and negative terminal of the circuit was tested to check for continuity in the circuit. The continuity test helps to check if the positive and negative terminal of the circuit is bridged or not bridged. The solar panel was placed under sunlight and was also connected to the appropriate input terminal of the circuit. To test for the different output voltages, a switch in the circuit was mounted to select the desired voltage and the multi-meter was probed on the output terminal. At low sunlight, the circuit gave output voltages of about 4.86V, 7.26V, and 8.18V respectively and at intense sunlight, the output voltages were 6.5V, 8V, and 14.6V respectively.

4.1 Reliability Test

The Panel was placed in sunlight and the appropriate output terminals were connected to a solar lantern and a Techno mobile phone as shown in Fig. 2 and Fig. 3, to test the charging reliability and capabilities. The charging of an empty mobile phone and a drained rechargeable lantern to their full capacity under direct charging between the hours of 10.00 am to 4.00 pm, has proven beyond any doubt that the universal solar charger will definitely meet the needs of the common man in Africa, especially Nigeria (remote areas or villages).



Figure 2. Solar battery charger charging a Techno mobile phone



Figure 3 Solar battery charger charging a solar lantern

V. Conclusion

The design and construction of an enhanced solar battery charger was achieved. The charger uses DC from the solar panel to charge up the connected appliances. The system as described here will easily handle the charging of electronic devices such as tablets and mobile phones, iPad, iPod, rechargeable lamp, outdoor activities such as camping and hiking and any type of electrical appliances that have voltage and full power rating within the range of 12 volts. Amazingly enough, this device is economical and very cheap to build, less than ₦5000. With this device in place, the certainty of efficient electronic device recharging is guaranteed. This device can bridge the gap of power failure especially in remote areas where electricity is a rare commodity.

Appendix A

The value of the limiting resistor for the LED is given as:

$$R_s = \frac{V_s - V_D}{I_f}$$

Where $V_s = 18v$, $V_D = 2v$ (for Red LED), $I_f = 20mA$

$$R_s = \frac{18v - 2v}{20mA} = 800\Omega$$

The maximum power comes into effect when charging a 12v battery at 1.5A

Battery voltage = 12V, solar panel voltage = 18V

Therefore power is given as:

$$P = 18v - \frac{12v}{1.5A} = 9W$$

So thermally, the power is carefully matched to the current rating.

Adjusting the trimmers in the circuit gives the desired output voltage and the formula for the output voltages is given as:

$$V_{(out)} = 1.25v * \left(1 + \left(\frac{R_2}{R_1} \right) \right) + 100_{\mu F} * R_2$$

Setting the first trim pot to about 500 Ω will yield:

$$V_{(out)} = 1.25v * (1 + (500/120)) + 100_{\mu F} * 500 = 6.5V$$

The second to about 330 Ω will give:

$$V_{(out)} = 1.25v * (1 + (330+330/12)) + 100_{\mu F} * (330 + 330) = 8V$$

Finally, tuning the third trim pot to about 200Ω will produce:

$$V(\text{out}) = 1.25V * (1 + ((1000 + 200)/120)) + 100\mu F * (1000 + 200) = 14.6V$$

References

- [1] Jordan Eske, "The history of Solar Panel Battery Chargers," 06/09/2010 (Retrieved 25/03/2016) [Online]. http://EzineArticles.com/expert/Jordan_Eske/518558 Article Source: <http://EzineArticles.com/4993066>
- [2] Morgan Bazilian, Ijeoma Onyeji, Michael Liebreich, Ian MacGill, Jennifer Chase, Jigar Shah, Dolf Gielen, Doug Arent, Doug Landfear, Shi Zhengron, Re-considering the economics of photovoltaic power. *Renewable Energy* 53 (2013) 329e338 0960-1481/\$ <http://dx.doi.org/10.1016/j.renene.2012.11.029>
- [3] Generating Solutions, A Report of the U.S. PIRG Education Fund and the State, Public Interest Research Groups, www.pirg.org. February 2002,
- [4] Razykov, T.M., Ferekides, C.S., Morel, D., Stefanakos, E., Ullal, H.S., Upadhyaya H.M., Solar photovoltaic electricity: Current status and future prospects, *Solar Energy* 85 (2011) 1580–1608 0038-092X/\$ Elsevier Ltd. doi:10.1016/j.solener.2010.12.002
- [5] Nelson A. Kelly, Thomas L. Gibson Increasing the solar photovoltaic energy capture on sunny and cloudy days *Solar Energy* 85 (2011) 111–125 0038-092X/\$ Elsevier Ltd. doi:10.1016/j.solener.2010.10.015
- [6] John, Keit, "Solar Battery Charger Circuit", <http://www.electroschematics.com/6888/> [Online] (Retrieved 08/04/2015)
- [7] John, Swagatam, "Homemade circuit projects 6V, 12, 24V battery Charger Circuit", [Online]. <http://www.homemade-circuits.com/2012/02> (Retrieved 07/23/2015)
- [8] Oscar, Den, "A Solar battery charger", <http://www.den-uijl.nl/> (2013) [Online] (Retrieved on May 15, 2015)
- [9] A.A. Azooz, J.M. Sulayman (2007), "Electronic Control Circuit For Solar Battery Charging", *Romanian Reports in Physics*, Vol. 59, No. 1, PP. 101–111, 2007
- [10] Andy, Collinson, "Solar Battery Charger", <http://www.zen22142.zen.co.uk/> (2014) [Online] (Retrieved 08/14, 2015)
- [11] Electroshub, (2015). "Solar Battery Charger Circuit using LM317 Voltage Regulator", <http://www.electronicshub.org/solar-battery-charger-circuit/> [Online] (Retrieved 07/ 15/ 2015)
- [12] Reuk Shop, (2015). "Solar Battery Charger with LM317T – solar", [Online] <http://www.reuk.co.uk/> (Retrieved 05/28/ 2015)